

ASSEMBLY INSTRUCTIONS
FOR
DYNALITE BIG BRAKE FRONT HAT KIT, 12.19" DIAMETER VENTED ROTOR
2002 - 2003 ACURA RSX (5 LUG)
FOR FACTORY 262 mm DISC SPINDLE

PART NUMBER GROUP

140-7014

**DISC BRAKES SHOULD ONLY BE INSTALLED BY SOMEONE
EXPERIENCED AND COMPETENT IN THE INSTALLATION
AND MAINTENANCE OF DISC BRAKES**

READ ALL WARNINGS

WARNING

IT IS THE RESPONSIBILITY OF THE PERSON INSTALLING ANY BRAKE COMPONENT OR KIT TO DETERMINE THE SUITABILITY OF THE COMPONENT OR KIT FOR THAT PARTICULAR APPLICATION. IF YOU ARE NOT SURE HOW TO SAFELY USE THIS BRAKE COMPONENT OR KIT, YOU SHOULD NOT INSTALL OR USE IT. DO NOT ASSUME ANYTHING. IMPROPERLY INSTALLED OR MAINTAINED BRAKES ARE DANGEROUS. IF YOU ARE NOT SURE, GET HELP OR RETURN THE PRODUCT. YOU MAY OBTAIN ADDITIONAL INFORMATION AND TECHNICAL SUPPORT BY CALLING WILWOOD AT (805) 388-1188, OR VISIT OUR WEB SITE AT WWW.WILWOOD.COM. USE OF WILWOOD TECHNICAL SUPPORT DOES NOT GUARANTEE PROPER INSTALLATION. YOU, OR THE PERSON WHO DOES THE INSTALLATION MUST KNOW HOW TO PROPERLY USE THIS PRODUCT. IT IS NOT POSSIBLE OVER THE PHONE TO UNDERSTAND OR FORESEE ALL THE ISSUES THAT MIGHT ARISE IN YOUR INSTALLATION.

RACING EQUIPMENT AND BRAKES MUST BE MAINTAINED AND SHOULD BE CHECKED REGULARLY FOR FATIGUE, DAMAGE, AND WEAR.



WARNING

DO NOT OPERATE ANY VEHICLE ON UNTESTED BRAKES!
SEE MINIMUM TEST PROCEDURE WITHIN

ALWAYS UTILIZE SAFETY RESTRAINT SYSTEMS AND ALL OTHER AVAILABLE SAFETY EQUIPMENT WHILE OPERATING THE VEHICLE.

IMPORTANT • READ THE DISCLAIMER OF WARRANTY INCLUDED IN THE KIT.

NOTE: Some cleaners may stain or remove the finish on brake system components. Test the cleaner on a hidden portion of the component before general use.

Important Notice - Read This First

Before any tear-down or disassembly begins, review the following information:

- Review the wheel clearance diagram (figure 2, page 3) to verify that there is adequate clearance with the wheels you will be using with the installation.
- Front brake kits do not include flex lines. OEM brake lines will not adapt to Wilwood calipers. Check the assembly instructions, or associated components section for brake line recommendations before assembly. In addition, Wilwood offers an extensive listing of brake lines and fitting on our web site: www.wilwood.com.
- Due to OEM production differences and other variations from vehicle to vehicle, the fastener hardware and other components in this kit may not be suitable for a specific application or vehicle.
- It is the responsibility of the purchaser and installer of this kit to verify suitability / fitment of all components and ensure all fasteners and hardware achieve complete and proper engagement. Improper or inadequate engagement can lead to component failure.

Exploded Assembly Diagram and Parts List

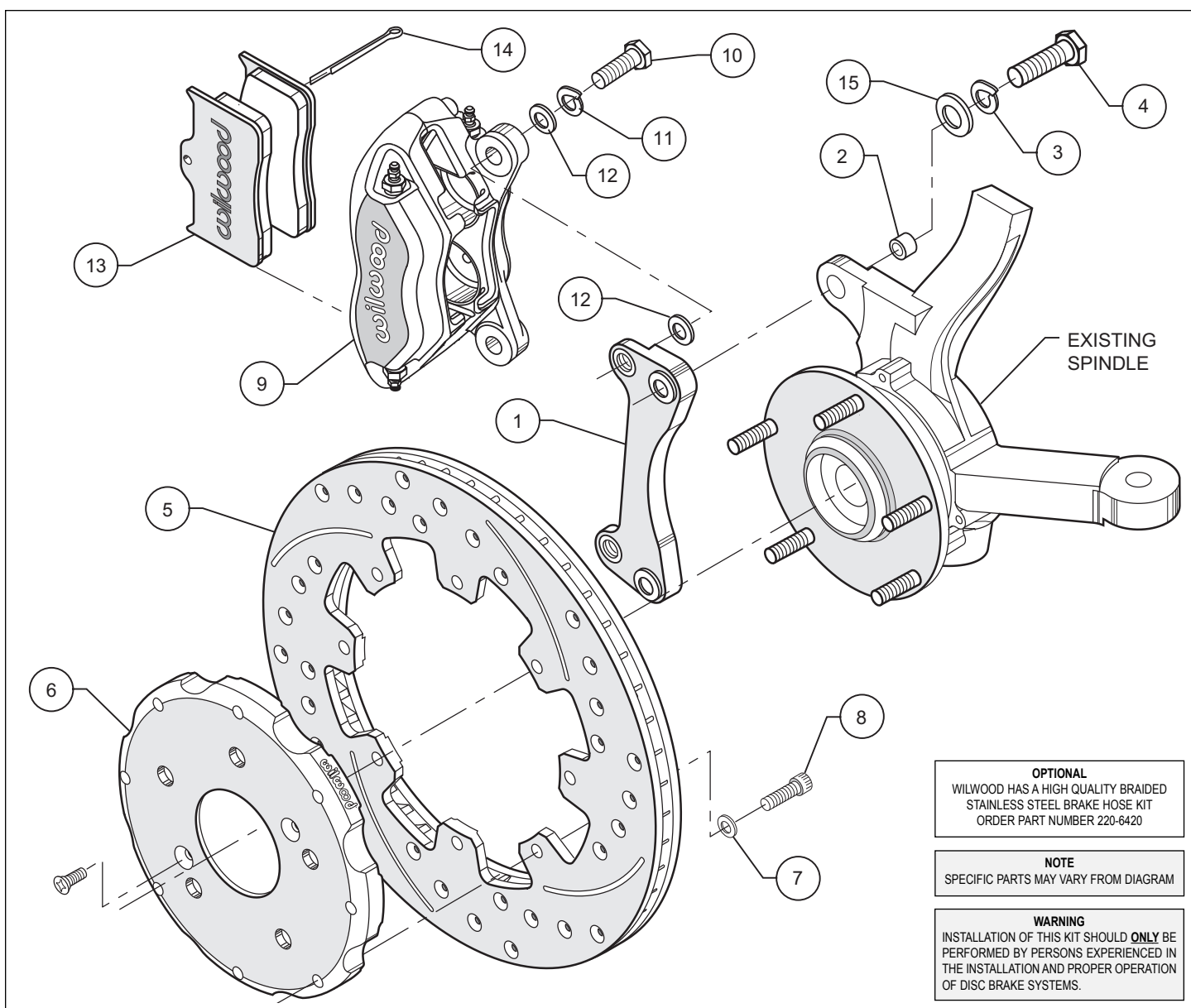

Figure 1. Typical Installation Configuration, Left Hand Application Shown

Parts List

ITEM NO.	PART NO.	DESCRIPTION	QTY
1	250-6289	Bracket, Caliper Mounting	2
2	300-6347	Sleeve	4
3	240-0139	Washer, Lock 3/4 inch	4
4	230-6321	Bolt, 7/16-20 x 1.25 Long	4
5	160-7103/04	Rotor, .81" Thk x 12.19" Dia, 8 x 7.00" Bolt Circle, Drilled & Slotted	2
6	170-6947	Hat	2
7	240-0541	Washer, 9/16 inch	8
8	230-0438	Bolt, 5/16-18 x 1.00 Long	8
9	120-6806	Caliper, Forged Dynalite	2
10	230-0228	Bolt, 3/8-24 x 1.25 Long	4
11	240-0140	Washer, Lock 11/16 inch	4
12	240-1159	Shim, .035 thick	16
13	150-8850K	Pad, BP-10, Axle Set	1
14	180-0054S	Pin, Cotter	2
15	240-1848	Shim Washer, .03 thick	4
Optional	220-6860	Braided Stainless Steel Hose Kit (Not Included)	

NOTES:

Part Number 230-6365 Rotor Bolt Kit, includes part numbers 230-0438 and 240-0541

Part Number 230-7007 Caliper Bracket Mounting Bolt Kit, includes P/N's 230-6321, 240-0139, 240-1848 and 300-6347

Part Number 230-0204 Caliper Mounting Bolt Kit, includes P/N's 230-0228, 240-0140 and 240-1159

General Information, Disassembly and Assembly Instructions

Installation of this kit should **ONLY** be performed by persons experienced in the installation and proper operation of disc brake systems. Before installation begins, please read the complete procedure thoroughly to familiarize yourself with the process, and double check the following items to ensure a trouble-free installation.

- Make sure this is the correct kit to match the exact make and model year of the vehicle's spindle (i.e., brackets for a 1995 Acura spindle will not fit a 2002 Acura spindle).
- Verify the hat stud pattern in this kit matches the stud pattern of the vehicle's wheels.
- Verify your wheel clearance using Figure 2.
- Inspect the package contents against the parts list to ensure that all components and hardware are included.

Disassembly

- Disassemble the original equipment front brakes:
Raise the front wheels off the ground. The vehicle's weight must be on jack stands and not supported by a car jack or hoist.

Remove the wheel. Disconnect the caliper brake hose from the brake line at the body. Remove the two bolts that hold the stock caliper mounting bracket to the spindle. Lift off the bracket and stock caliper as one unit, then slide off the stock hat and rotor assembly. On some models you may have to unbolt the stock caliper from the caliper bracket before removal.

- Thoroughly clean the spindles.

Assembly Instructions (numbers in parenthesis refer to the part list/diagram on the preceding page): **CAUTION:** All mounting bolts must fully engage insert nuts. Be sure to check that all bolts are either flush or protruding through flanged side of insert nut after shimming.

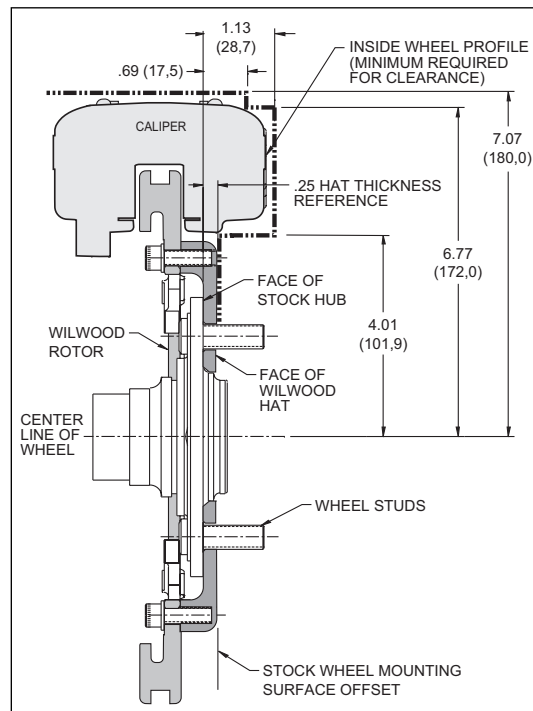

Figure 2. Wheel Clearance Diagram

Assembly Instructions (Continued)

- Insert one sleeve (2) each into the holes on the top and bottom of the spindle “ears” where the OEM caliper bracket was removed. Apply red *Loctite*® 271 to the caliper mounting bracket bolt threads (4) before installation of the caliper mounting bracket (1). Install the caliper mounting bracket (1) with the threaded inserts and the beveled bolt holes facing the outside of the vehicle. Slide bolt (4) through lock washer (3) and shim (15) into the previously installed insert (2) from the backside of the spindle. Finger tighten. Repeat for the lower mounting holes. Torque bolts to 47 ft-lb. **NOTE:** Be sure the heads of the caliper bracket (1) insert nuts are facing outward toward the wheel.

- With the larger I.D. side of the rotor (5) facing away from the hat (6), bolt rotor (5) to hat (6) through the backside of the rotor using washers (7) and bolts (8). Torque bolts (8) to 120-144 **in-lb**. Safety wire bolts (8) using standard 0.032 inch diameter stainless steel safety wire as shown in Figure 3. Please refer to Wilwood’s data sheet DS-386 (available at www.wilwood.org/ds386.pdf) for complete safety wire installation instructions. Slide the rotor/hat assembly onto the spindle. Install a couple of lug nuts (finger tighten) to keep the rotor/hat assembly in place while continuing with the installation.

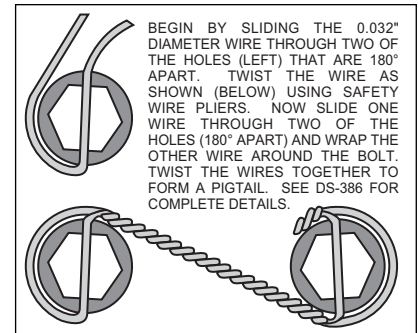

Figure 3. Safety Wire Diagram

- NOTE:** Please reference the caution statement at the beginning of the assembly instructions. With the bleed screws pointing up, mount the caliper (9) onto the caliper mounting bracket (1) using two bolts (10), two lock washers (11) and two shims (12). View the rotor (5) through the top of the caliper (9). The rotor (6) should be aligned in the center of the caliper (9). If not, loosen the two bolts (10) and adjust the caliper (9) by using 0.035 inch thick shim washers (12). The shim washers (12) should be placed between the caliper (9) and the caliper mounting bracket (1). Finger tighten and recheck alignment. Add as many shim washers (12) as necessary to achieve the correct alignment. Always use the same amount of shims on both the top and bottom caliper mounting bolts (10). Loosen the two bolts (10) and apply red *Loctite*® 271 to bolt threads (10) and torque to 30 ft-lb. Safety wire the two bolts (10).

- Install the disc brake pads (13) and secure using cotter pin (14). Repeat this procedure for the other wheel.

- Bleed the brake system. Reference the general information and recommendations on page 5 for proper bleeding instructions.

- Remove the two lug nuts that were used to hold the rotor/hat assembly in place during caliper installation. Install the wheel and lug nuts, torque to OEM specifications.

- NOTE:** OEM rubber brake hoses will not adapt to Wilwood calipers and should not be used. The caliper inlet fitting is a 1/8-27 NPT. Use steel adapter fittings at the caliper, either straight, 45 or 90 degree and enough steel braided line to allow for full suspension travel and turning radius, lock to lock. **Carefully route lines to prevent contact with moving suspension, brake, or wheel components.** Periodically check hose and components for any wear. Wilwood brake and hose kits are designed for use in many different vehicle applications and it is the installer’s responsibility to properly route and ensure adequate clearance and retention for brake hose components. Wilwood offers a hose kit, P/N 220-6860, which includes hoses, fittings, etc., all in one package.

Additional Information and Recommendations

•**NOTE:** With the installation of after market disc brakes, the wheel track may change depending on the application. Check your wheel offset before final assembly.

•Please read the following concerning balancing the brake bias on 4 wheel disc vehicles.

This brake kit can be operated using the stock OEM master cylinder. However, as with most suspension and tire modifications (from OEM specifications), changing the brakes may alter the front to rear brake bias. Rear brakes should not lock up before the front. Brake system evaluation and tests should be performed by persons experienced in the installation and proper operation of brake systems. Evaluation and tests should be performed under controlled conditions. Start by making several stops from low speeds then gradually work up to higher speeds. Always utilize safety restraint systems while operating vehicle.

Use a Wilwood adjustable proportioning valve if necessary to achieve proper brake balance, or

Use a Wilwood brake pedal/balancebar assembly with dual master cylinders (requires custom mounting as used in fabricated chassis race cars). A balance bar brake system permits incremental front to rear brake pressure adjustments.

•For optimum performance, fill and bleed the new system with Wilwood Hi-Temp^o 570 grade fluid or EXP 600 Plus. For severe braking or sustained high heat operation, use Wilwood EXP 600 Plus Racing Brake Fluid. Used fluid must be completely flushed from the system to prevent contamination. **NOTE:** Silicone DOT 5 brake fluid is **NOT** recommended.

•To properly bleed the brake system, begin with the caliper farthest from the master cylinder. Bleed the outboard bleed screw first, then the inboard. Repeat the procedure until all calipers in the system are bled, ending with the caliper closest to the master cylinder. If the caliper is fitted with bleed screws on four corners, make sure the bottom bleed screws are tight. Only bleed from the top bleed screws. **NOTE:** When using a new master cylinder, it is important to bench bleed the master cylinder first.

•If the master cylinder is mounted lower than the disc brake calipers, some fluid flowback to the master cylinder reservoir may occur, creating a vacuum effect that retracts the caliper pistons into the housing. This will cause the pedal to go to the floor on the first stroke until it has "pumped up" and moved all the pistons out against the pad again. A Wilwood in-line 2 lb. Residual Pressure Valve installed near the master cylinder will stop the fluid flowback and keep the pedal firm and responsive.

•Test the brake pedal. It should be firm, not spongy, and stop at least 1 inch from the floor under heavy load.

If the brake pedal is spongy, bleed the system again.

If the brake pedal is initially firm, but then sinks to the floor, check the system for leaks. Correct the leaks (if applicable) and then bleed the system again.

If the brake pedal goes to the floor and continued bleeding of the system does not correct the problem, either air may be trapped in the system, or a master cylinder with increased capacity (larger bore diameter) may be required. Wilwood offers various lightweight master cylinders with large fluid displacement capacities (custom fabricated mounting may be required).

•On some models of disc brake spindles there are "ears" where the OEM calipers were mounted that interfere with the assembly of the Wilwood disc brake kit. If "ear" removal is required, remove only what is necessary to clear the new bracket, retaining appropriate mounting bolt holes.

Brake Testing and Pad Bedding

WARNING • DO NOT DRIVE ON UNTESTED BRAKES BRAKES MUST BE TESTED AFTER INSTALLATION OR MAINTENANCE MINIMUM TEST PROCEDURE

- Make sure pedal is firm: Hold firm pressure on pedal for several minutes, it should remain in position without sinking. If pedal sinks toward floor, check system for fluid leaks. DO NOT drive vehicle if pedal does not stay firm or can be pushed to the floor with normal pressure.
- At very low speed (2-5 mph) apply brakes hard several times while turning steering from full left to full right, repeat several times. Remove the wheels and check that components are not touching, rubbing, or leaking.
- Carefully examine all brake components, brake lines, and fittings for leaks and interference.
- Make sure there is no interference with wheels or suspension components.
- Drive vehicle at low speed (15-20 mph) making moderate and hard stops. Brakes should feel normal and positive. Again check for leaks and interference.
- Always test vehicle in a safe place where there is no danger to (or from) other people or vehicles.
- Always wear seat belts and make use of all safety equipment.

PAD BEDDING PROCEDURE:

• Pump brakes at low speed to assure proper operation. On the race track, or other safe location, make a series of hard stops until some brake fade is experienced. Allow brakes to cool while driving at moderate speed to avoid use of the brakes. This process will properly burnish the brake pads, offering maximum performance.

Associated Components

PART NO.	DESCRIPTION
260-1874	Wilwood Residual Pressure Valve (2 lb for disc brakes)
260-1876	Wilwood Residual Pressure Valve (10 lb for drum brakes)
260-8419	Wilwood Proportioning Valve
290-0632	Wilwood Racing Brake Fluid (Hi-Temp° 570) (12 oz)
290-6209	Wilwood Racing Brake Fluid (EXP 600 Plus) (16.9 oz)
340-1285	Wilwood Floor Mount Brake Pedal (with balance bar)
340-1287	Wilwood Swing Mount Brake Pedal (with balance bar)
260-6764	Wilwood 3/4 inch High Volume Aluminum Master Cylinder
260-6765	Wilwood 7/8 inch High Volume Aluminum Master Cylinder
260-6766	Wilwood 1 inch High Volume Aluminum Master Cylinder
260-8555	Wilwood 1 inch Aluminum Tandem Chamber Master Cylinder
260-8556	Wilwood 1-1/8 inch Aluminum Tandem Chamber Master Cylinder
270-2016	Quick Release Steering Hub (3/4 inch shaft)
270-2017	Quick Release Steering Hub (5/8 inch shaft)
220-3509	Fitting, Straight (1/8-27 NPT to -3)
220-6412	Fitting, 45° Elbow (1/8-27 NPT to -3)
220-6413	Fitting, Adaptor Tubing (10mm to -3)
220-6415	Fitting, 90° Elbow (1/8-27 NPT to -3)

Bolt Torque Specifications

BOLT SIZE	TORQUE
1/4-20	85 in-lb
1/4-28	103 in-lb
5/16-18	180 in-lb
5/16-24	198 in-lb
3/8-16	22 ft-lb
3/8-24	30 ft-lb
7/16-14	42 ft-lb
7/16-20	47 ft-lb
1/2-13	65 ft-lb
1/2-20	77 ft-lb
9/16-12	95 ft-lb
9/16-18	105 ft-lb
5/8-11	110 ft-lb
5/8-18	120 ft-lb

NOTE: This bolt torque specification list is for use with specific grades of bolts as supplied in the particular Wilwood kit and is not intended as a guide for any other application.